

TAB MOWER

TAB MOWER **U1R-9** AND **U1-9**



Tab Mower is a **flooded** battery produced by using **Ca/Ca expanded metal manufacturing technology**.



Art. No.	Short code	Ah (C20)	EN (A)	Voltage (V)	Box type	L×W×H1/H2 (mm)	Total weight (kg)	Pcs/pallet (EUR/CNT)	BHD	Layout	Terminal	Remarks
217025	U1R-25	25	250	12	U1	196×127×159/185	7,2	96/130	B0	0	5	SMF,H
217125	U1-25	25	250	12	U1	196×127×159/185	7,2	96/130	B0	1	5	SMF,H
217032	U1R-32	32	350	12	U1	196×127×159/185	8,0	96/130	B0	0	5	SMF,H
217132	U1-32	32	350	12	U1	196×127×159/185	8,0	96/130	B0	1	5	SMF,H

The SMF lid with handle provides complete roll-over spill protection and the battery is **entirely maintenance free** throughout its life.

Layout 0

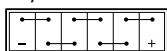

Layout 1

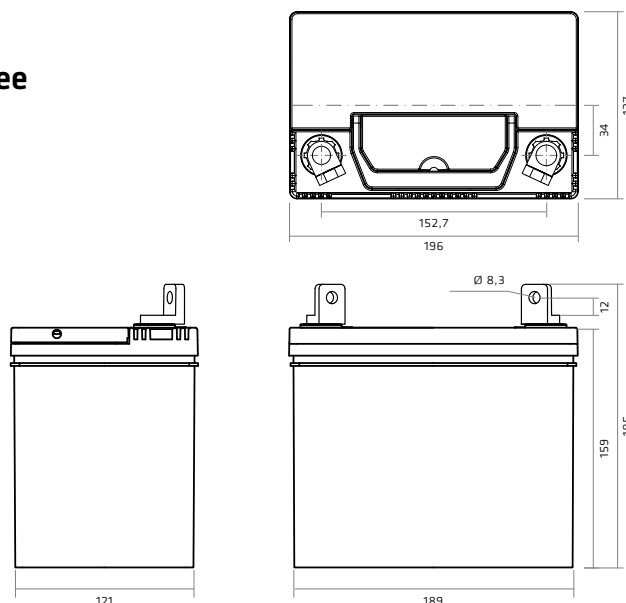
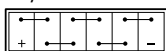

TDS U1R-9/U1-9 122015